

General Description

The ZM930P06D combines advanced trench MOSFET technology with a low resistance package to provide extremely low $R_{DS(ON)}$. This device is ideal for load switch and battery protection applications.

Features

- Advance high cell density Trench technology
- Low $R_{DS(ON)}$ to minimize conductive loss
- Low Gate Charge for fast switching
- Low Thermal resistance

Application

- MB/VGA Vcore
- SMPS 2nd Synchronous Rectifier
- POL application
- BLDC Motor driver

Product Summary

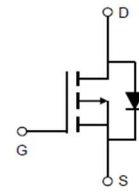

$V_{DS} = -60V$

$R_{DS(ON)} = 93m\Omega$

$I_D = -12A$

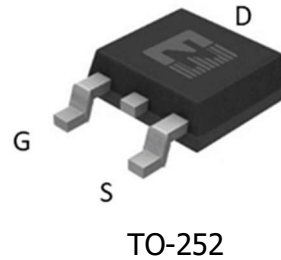

Ordering Information:

Part NO.	ZM930P06D
Marking	ZM930P06
Packing Information	REEL TAPE
Basic ordering unit (pcs)	2500

Absolute Maximum Ratings ($T_C = 25^\circ C$)

Parameter	Symbol	Rating	Unit
Drain-Source Voltage	V_{DS}	-60	V
Gate-Source Voltage	V_{GS}	± 20	V
Continuous Drain Current	$I_{D@TC=25^\circ C}$	-12	A
	$I_{D@TC=75^\circ C}$	-9	A
	$I_{D@TC=100^\circ C}$	7.5	A
Pulsed Drain Current ^①	I_{DM}	-30	A
Total Power Dissipation($TC=25^\circ C$)	$P_D@TC=25^\circ C$	50	W
Total Power Dissipation($TA=25^\circ C$)	$P_D@TA=25^\circ C$	1.25	W
Operating Junction Temperature	T_J	-55 to 150	$^\circ C$
Storage Temperature	T_{STG}	-55 to 150	$^\circ C$
Single Pulse Avalanche Energy	E_{AS}	40	mJ

•Thermal resistance

Parameter	Symbol	Min.	Typ.	Max.	Unit
Thermal resistance, junction - case	R_{thJC}	-	-	2.4	$^{\circ}C/W$
Thermal resistance, junction - ambient	R_{thJA}	-	-	65	$^{\circ}C/W$
Soldering temperature, wavesoldering for 10s	T_{sold}	-	-	265	$^{\circ}C$

•Electronic Characteristics

Parameter	Symbol	Condition	Min.	Typ.	Max.	Unit
Drain-Source Breakdown Voltage	BV_{DSS}	$V_{GS} = 0V, I_D = -250\mu A$	-60			V
Gate Threshold Voltage	$V_{GS(TH)}$	$V_{GS} = V_{DS}, I_D = -250\mu A$	-1.2		-2.5	V
Drain-Source Leakage Current	I_{DSS}	$V_{DS} = -60V, V_{GS} = 0V$			1.0	μA
Gate- Source Leakage Current	I_{GSS}	$V_{GS} = \pm 20V, V_{DS} = 0V$			± 100	nA
Static Drain-source On Resistance	$R_{DS(ON)}$	$V_{GS} = -10V, I_D = -12A$		93	120	m Ω
		$V_{GS} = -4.5V, I_D = -10A$		128	166	m Ω
Forward Transconductance	g_{FS}	$V_{DS} = -10V, I_D = -2A$		10		S
Source-drain voltage	V_{SD}	$I_S = -12A$			1.28	V

•Electronic Characteristics

Parameter	Symbol	Condition	Min.	Typ.	Max.	Unit
Input capacitance	C_{iss}	$V_{DS} = -25V$ $f = 1MHz$	-	650	-	pF
Output capacitance	C_{oss}		-	120	-	
Reverse transfer capacitance	C_{rss}		-	70	-	

•Gate Charge characteristics($T_a = 25^{\circ}C$)

Parameter	Symbol	Condition	Min.	Typ.	Max.	Unit
Total gate charge	Q_g	$V_{DD} = -25V$	-	12	-	nC
Gate - Source charge	Q_{gs}	$I_D = -5A$	-	4	-	
Gate - Drain charge	Q_{gd}	$V_{GS} = -10V$	-	6	-	

Note: ① Pulse Test : Pulse width $\leq 300\mu s$, Duty cycle $\leq 2\%$;

Fig.1 Power Dissipation Derating Curve

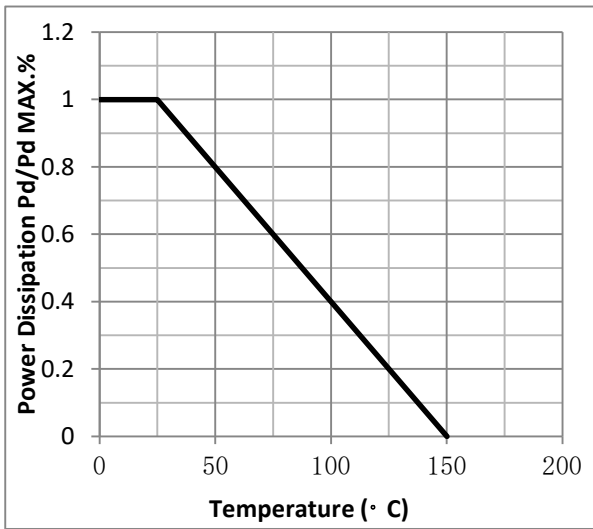

Fig.2 Typical output Characteristics

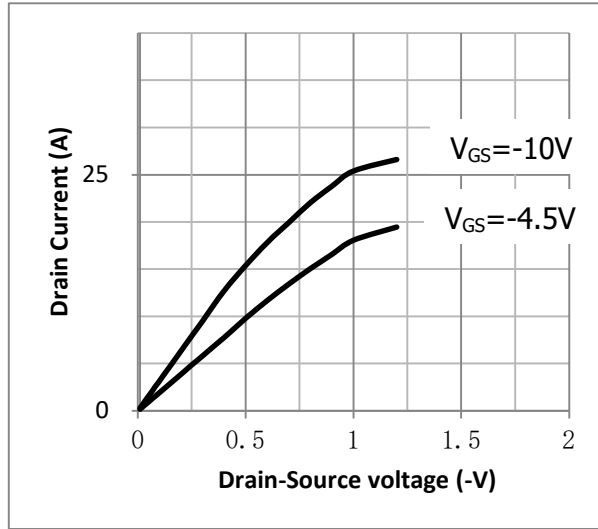

Fig.3 Threshold Voltage V.S Junction Temperature

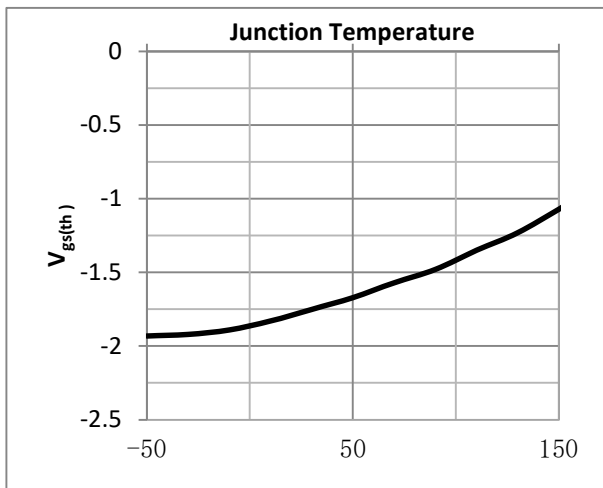

Fig.4 Resistance V.S Drain Current

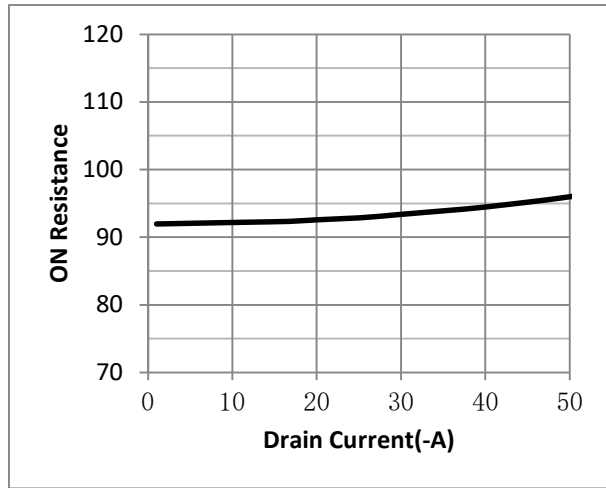

Fig.5 On-Resistance VS Gate Source Voltage

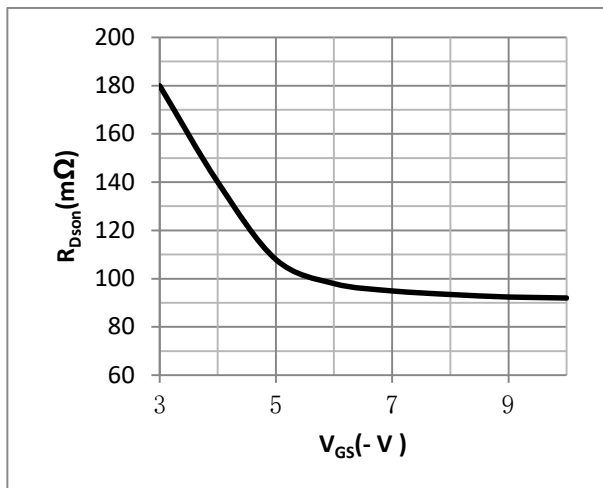

Fig.6 On-Resistance V.S Junction Temperature

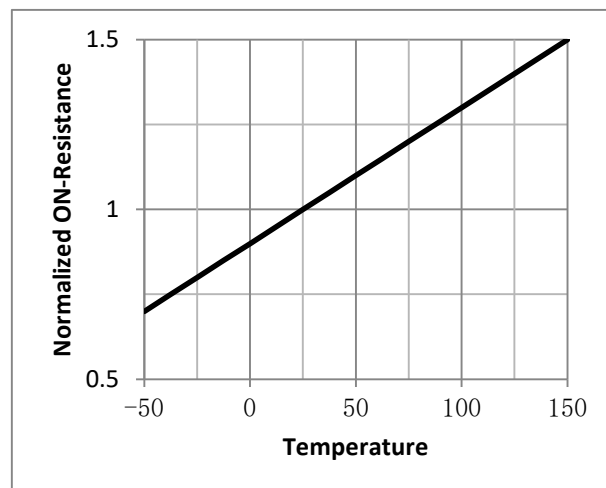

Fig.7 Gate Charge Measurement Circuit

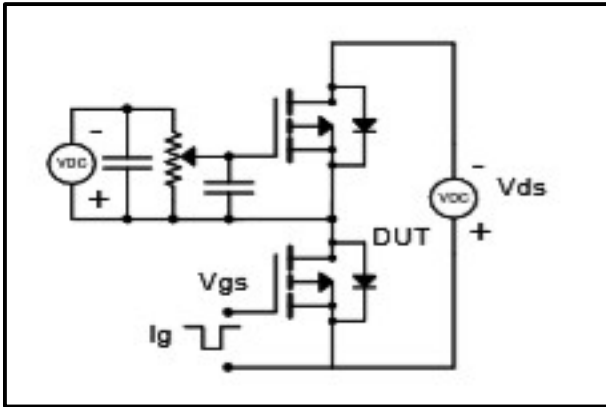

Fig.8 Gate Charge Waveform

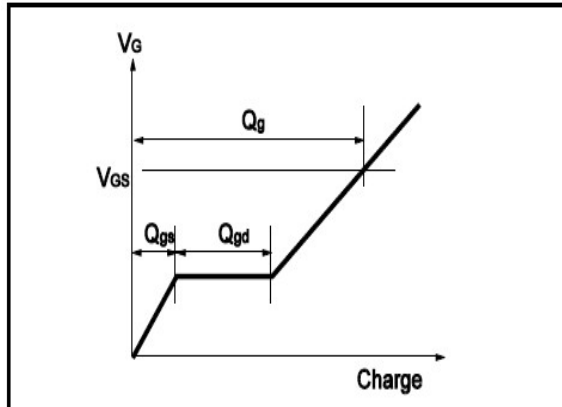

Fig.9 Switching Time Measurement Circuit

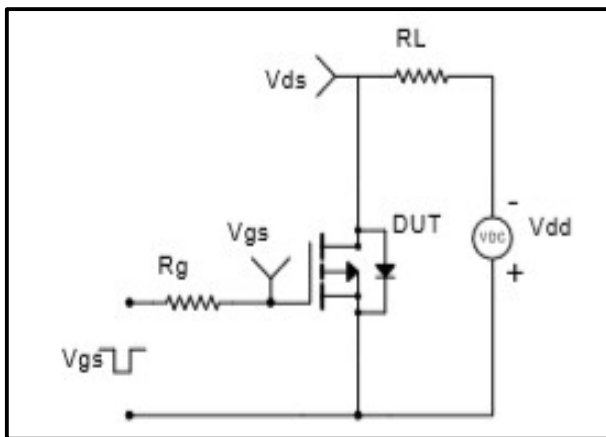

Fig.10 Switching Time Waveform

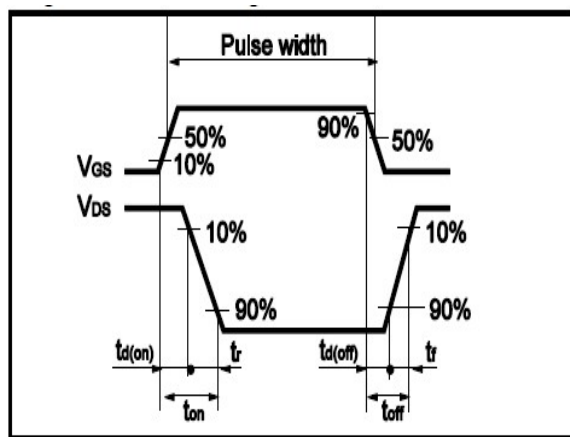

Fig.11 Avalanche Measurement Circuit

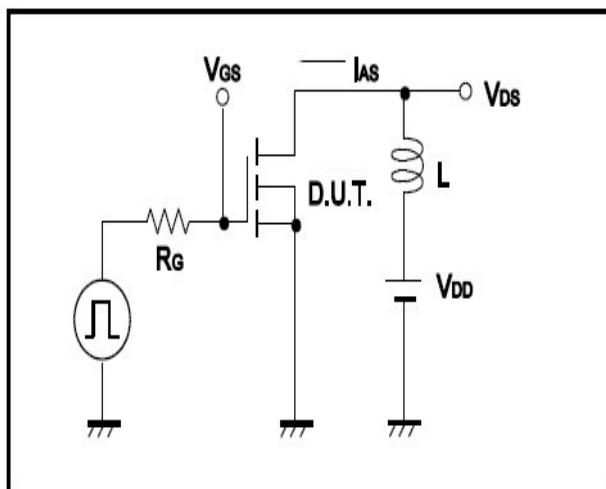
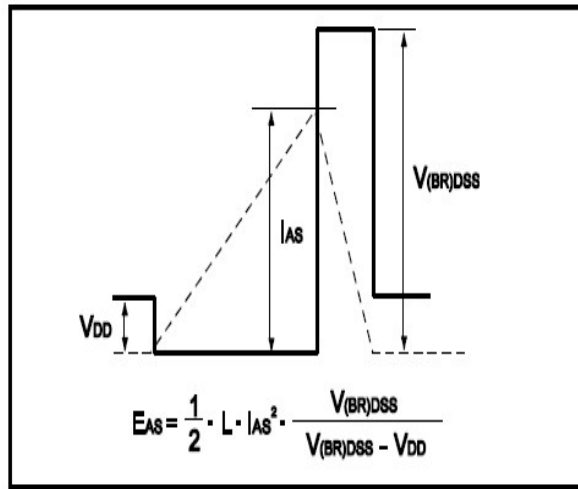
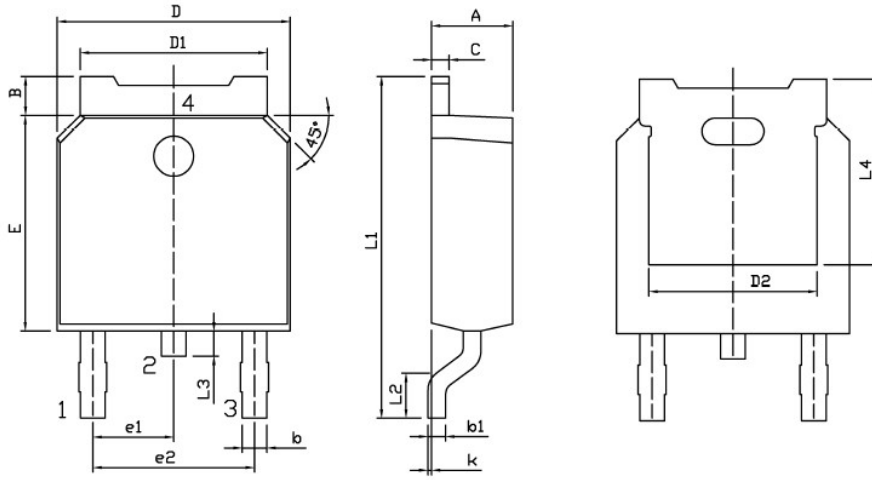

Fig.12 Avalanche Waveform





•Dimensions(TO-252)



Land Pattern
(Only for Reference)

Dimensions In Millimeters					
Symbol	MIN	MAX	Symbol	MIN	MAX
A	2.20	2.40	E	5.95	6.25
B	0.95	1.25	e1	2.24	2.34
b	0.70	0.90	e2	4.43	4.73
b1	0.45	0.55	L1	9.85	10.35
C	0.45	0.55	L2	1.70	2.00
D	6.45	6.75	L3	0.60	0.90
D1	5.10	5.50	L4	5.05	
D2	4.85		k	0.00	0.10

